

THIS DRAWING IS UNPUBLISHED. RELEASED FOR PUBLICATION 20  
 © COPYRIGHT 20 BY - ALL RIGHTS RESERVED.

| LOC |     | DIST                      |           | REVISIONS |      |  |  |
|-----|-----|---------------------------|-----------|-----------|------|--|--|
| P   | LTR | DESCRIPTION               | DATE      | DWN       | APVD |  |  |
|     | H6  | REVISED PER ECO-11-005027 | 14MAR2011 | RK        | HMR  |  |  |

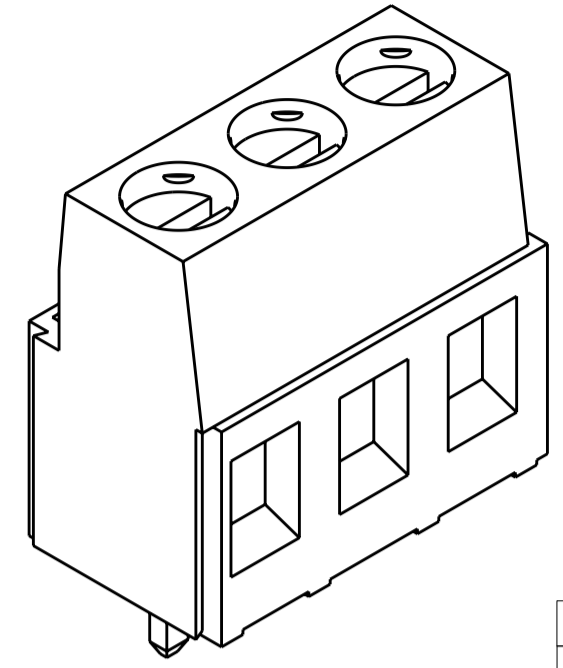
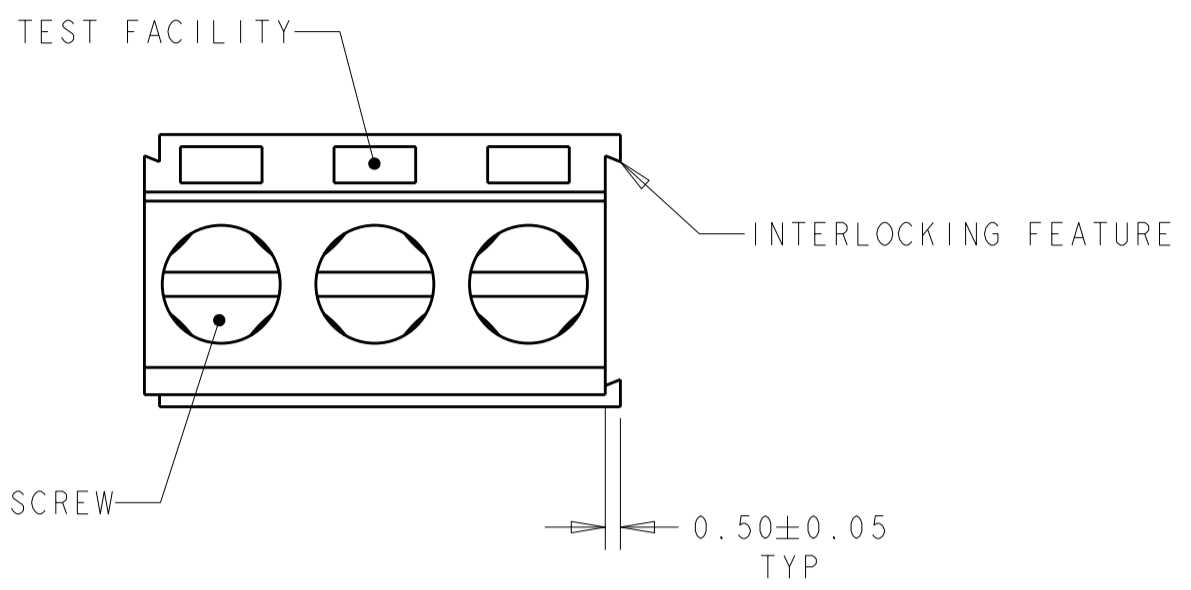

282841-3 AS SHOWN PRELIMINARY

| DETAIL         | DESCRIPTION | MATERIAL        | WEIGHT      | COLOR      | NO OF POSN  | PART NUMBER |            |
|----------------|-------------|-----------------|-------------|------------|-------------|-------------|------------|
| PRELIMINARY    |             |                 | SEE SHEET 2 | GREEN      | 15.24       | 3           | 4-282841-0 |
| DETAIL C       | PRELIMINARY | -               | -           | GREEN      | 25.40       | 5           | 3-282841-9 |
| DETAIL B       | PRELIMINARY | -               | -           | GREEN      | 20.32       | 4           | 3-282841-8 |
| PRELIMINARY    |             | STAINLESS STEEL | -           | GREEN      | 40.64       | 8           | 3-282841-7 |
| PRELIMINARY    |             | STAINLESS STEEL | -           | GREEN      | 20.32       | 4           | 3-282841-6 |
| PRELIMINARY    |             | STAINLESS STEEL | -           | GREEN      | 15.24       | 3           | 3-282841-5 |
| PRELIMINARY    |             | STAINLESS STEEL | -           | GREEN      | 10.16       | 2           | 3-282841-4 |
|                |             |                 | SEE SHEET 2 | GREEN      | 45.72       | 9           | 3-282841-3 |
|                |             |                 | SEE SHEET 2 | GREEN      | 66.04       | 13          | 3-282841-2 |
|                |             |                 | SEE SHEET 2 | GREEN      | 20.32       | 4           | 3-282841-1 |
|                |             |                 | SEE SHEET 2 | GREEN      | 60.96       | 12          | 3-282841-0 |
|                |             |                 | -           | BLACK      | 127.0       | 25          | 2-282841-9 |
|                |             |                 | -           | GREEN      | 127.0       | 25          | 2-282841-8 |
|                |             |                 | -           | GREEN      | 121.92      | 24          | 2-282841-7 |
|                |             |                 | -           | GREEN      | 116.84      | 23          | 2-282841-6 |
|                |             |                 | -           | GREEN      | 111.76      | 22          | 2-282841-5 |
|                |             |                 | -           | GREEN      | 106.68      | 21          | 2-282841-4 |
|                |             |                 | -           | GREEN      | 101.60      | 20          | 2-282841-3 |
|                |             |                 | -           | GREEN      | 96.52       | 19          | 2-282841-2 |
|                |             |                 | -           | GREEN      | 91.44       | 18          | 2-282841-1 |
|                |             |                 | -           | GREEN      | 86.36       | 17          | 2-282841-0 |
|                |             |                 | -           | GREEN      | 81.28       | 16          | 1-282841-9 |
|                |             |                 | -           | GREEN      | 76.20       | 15          | 1-282841-8 |
|                |             |                 | -           | GREEN      | 71.12       | 14          | 1-282841-7 |
|                |             |                 | -           | GREEN      | 66.04       | 13          | 1-282841-6 |
|                |             |                 | SEE SHEET 2 | GREEN      | 40.64       | 8           | 1-282841-5 |
|                |             |                 | SEE SHEET 2 | GREEN      | 35.56       | 7           | 1-282841-4 |
|                |             |                 | -           | BLACK      | 35.56       | 7           | 1-282841-3 |
|                |             |                 | -           | GREEN      | 60.96       | 12          | 1-282841-2 |
|                |             |                 | -           | GREEN      | 55.88       | 11          | 1-282841-1 |
|                |             |                 | -           | GREEN      | 50.80       | 10          | 1-282841-0 |
|                |             |                 | -           | GREEN      | 45.72       | 9           | 282841-9   |
|                |             |                 | -           | GREEN      | 40.64       | 8           | 282841-8   |
|                |             |                 | -           | GREEN      | 35.56       | 7           | 282841-7   |
|                |             |                 | -           | GREEN      | 30.48       | 6           | 282841-6   |
|                |             |                 | -           | GREEN      | 25.40       | 5           | 282841-5   |
|                |             |                 | -           | GREEN      | 20.32       | 4           | 282841-4   |
|                |             |                 | -           | GREEN      | 15.24       | 3           | 282841-3   |
|                |             |                 | -           | GREEN      | 10.16       | 2           | 282841-2   |
| CLAMPING SCREW | MARKING     | COLOR           | A           | NO OF POSN | PART NUMBER |             |            |

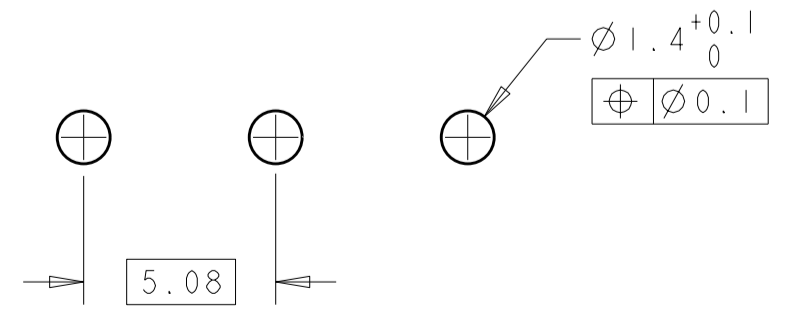
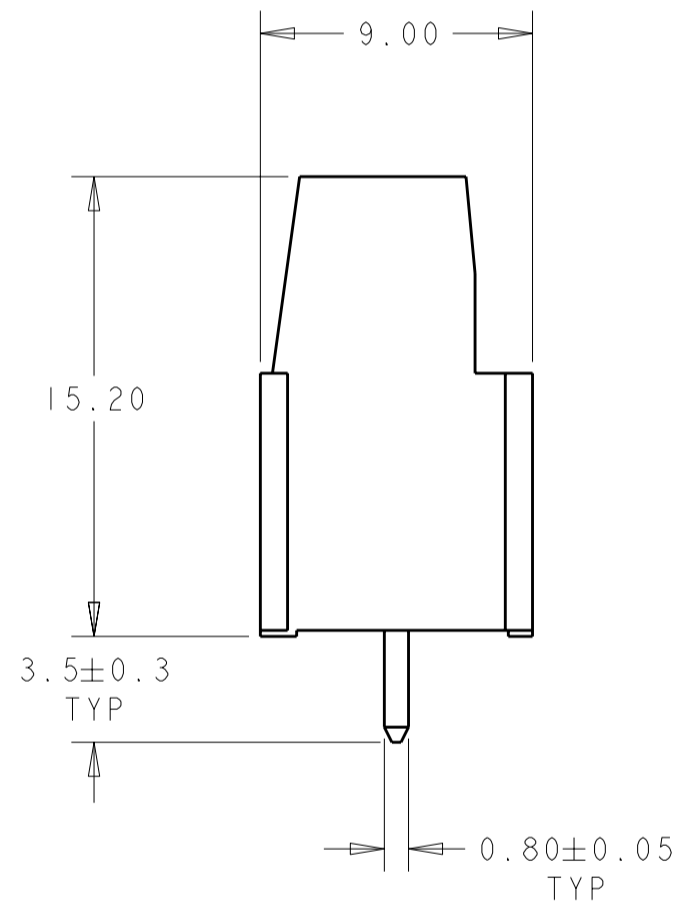
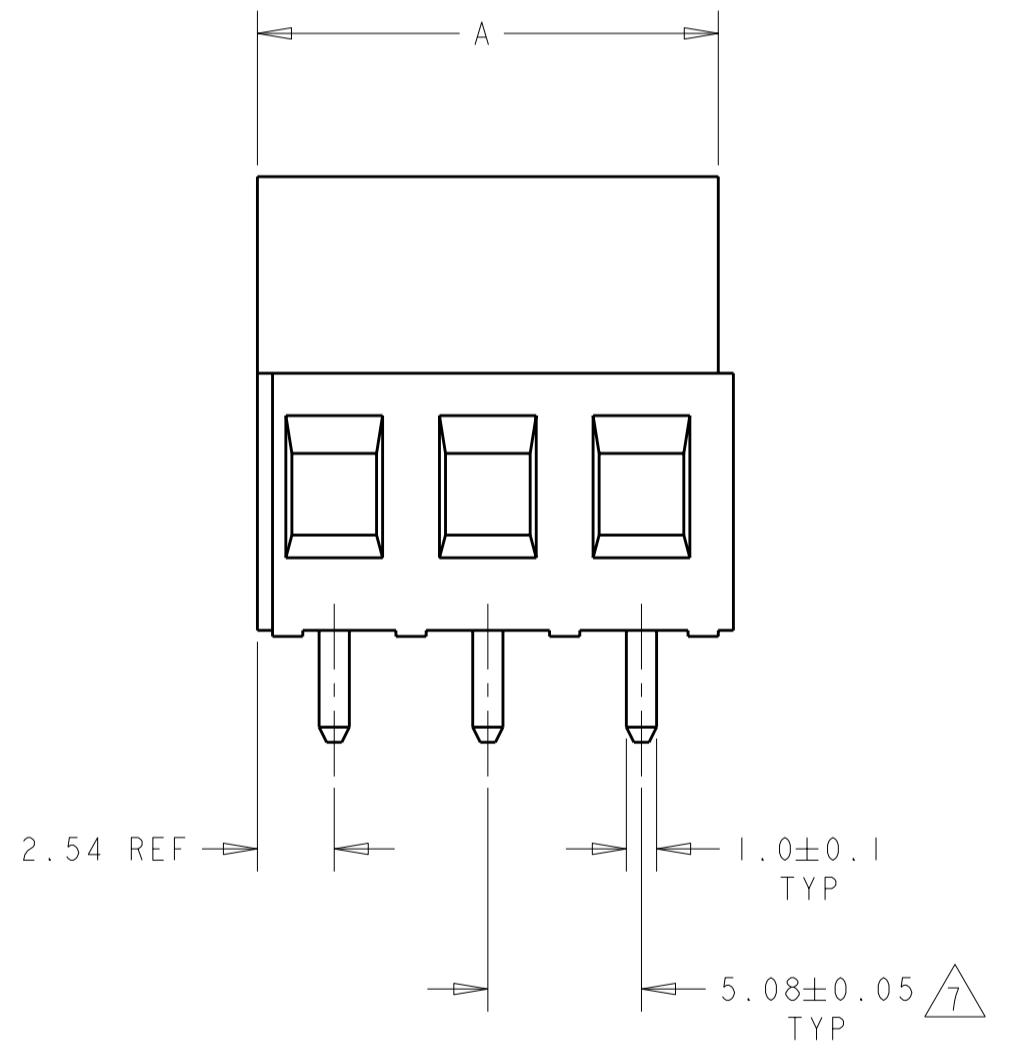

RECOMMENDED PC BOARD LAYOUT SCALE 5:1

THIS DRAWING IS A CONTROLLED DOCUMENT.

DWN S. WELDON 26 JAN 2001  
 CHK D. BIEVENOUR 26 JAN 2001  
 APVD D. BIEVENOUR 26 JAN 2001

STE TE Connectivity

NAME: TERMINAL BLOCK PCB MOUNT W/INTERLOCK, 5.08mm PITCH

SIZE: A2 CAGE CODE: 200779 DRAWING NO: 282841 RESTRICTED TO: -

MATERIAL: 1 TOLERANCES UNLESS OTHERWISE SPECIFIED: 0 PLC ±0, 1 PLC ±.3, 2 PLC ±.25, 3 PLC ±0, 4 PLC ±0 ANGLES FINISH ±2°

WEIGHT: -

CUSTOMER DRAWING SCALE: 4:1 SHEET 1 OF 2 REV: H6

THIS DRAWING IS UNPUBLISHED. RELEASED FOR PUBLICATION 20  
 © COPYRIGHT 20 BY - ALL RIGHTS RESERVED.

| LOC | DIST | REVISIONS   |             |     |      |
|-----|------|-------------|-------------|-----|------|
| P   | LTR  | DESCRIPTION | DATE        | DWN | APVD |
| FT  | 0    | -           | SEE SHEET 1 | -   | -    |
|     |      |             |             |     |      |
|     |      |             |             |     |      |

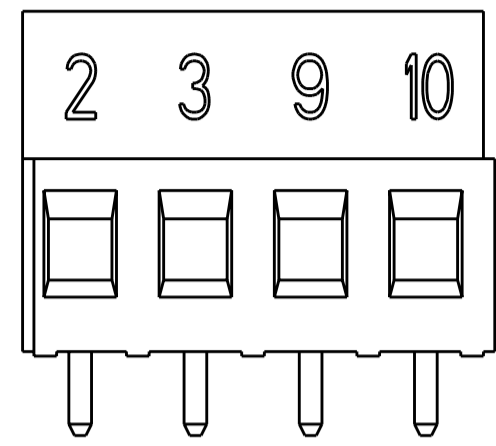

3-282841-1 AS SHOWN  $\triangle 8$

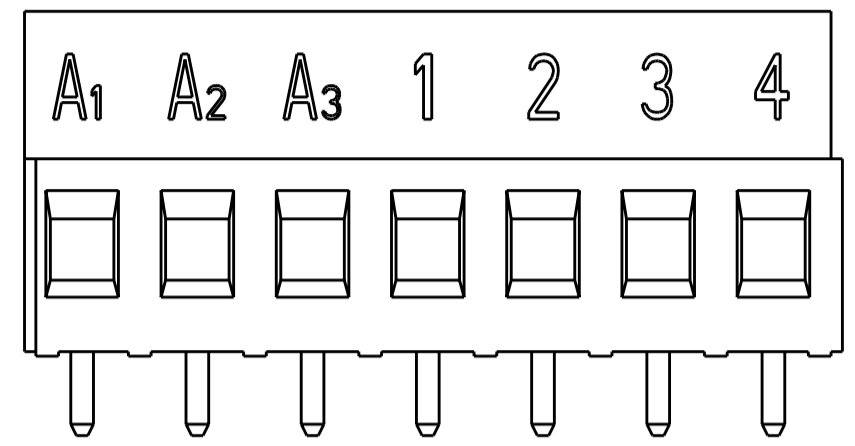

1-282841-4 AS SHOWN  $\triangle 8$

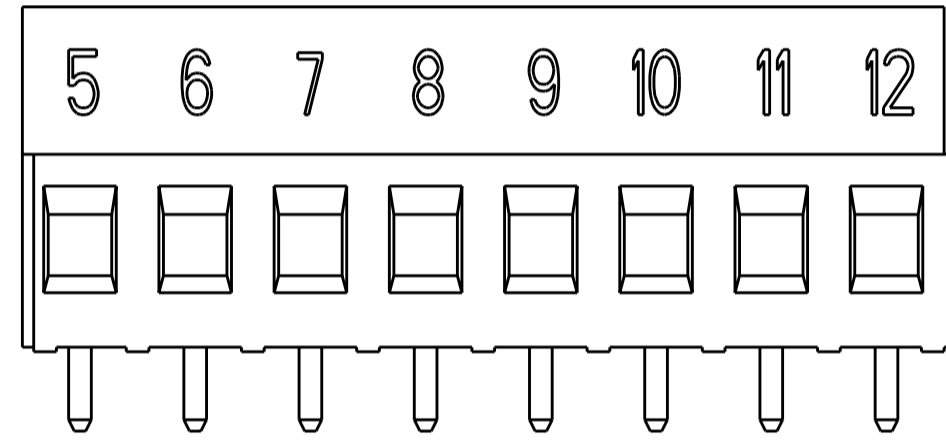

1-282841-5 AS SHOWN  $\triangle 8$

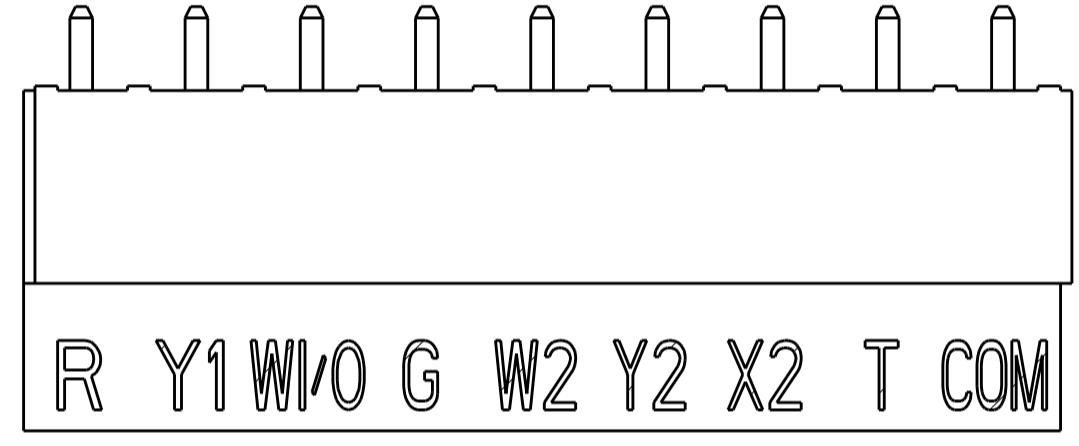

3-282841-3 AS SHOWN  $\triangle 8$

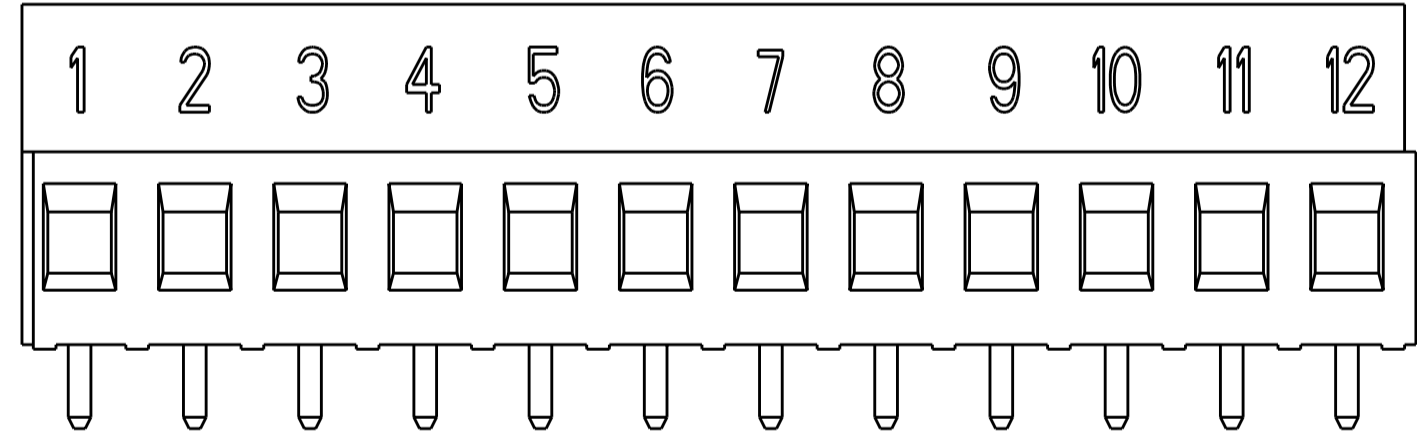

3-282841-0 AS SHOWN  $\triangle 8$

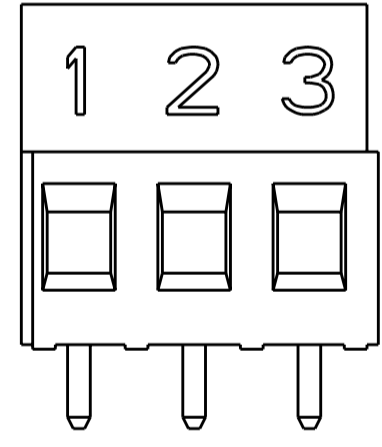

4-282841-0 AS SHOWN  $\triangle 8$

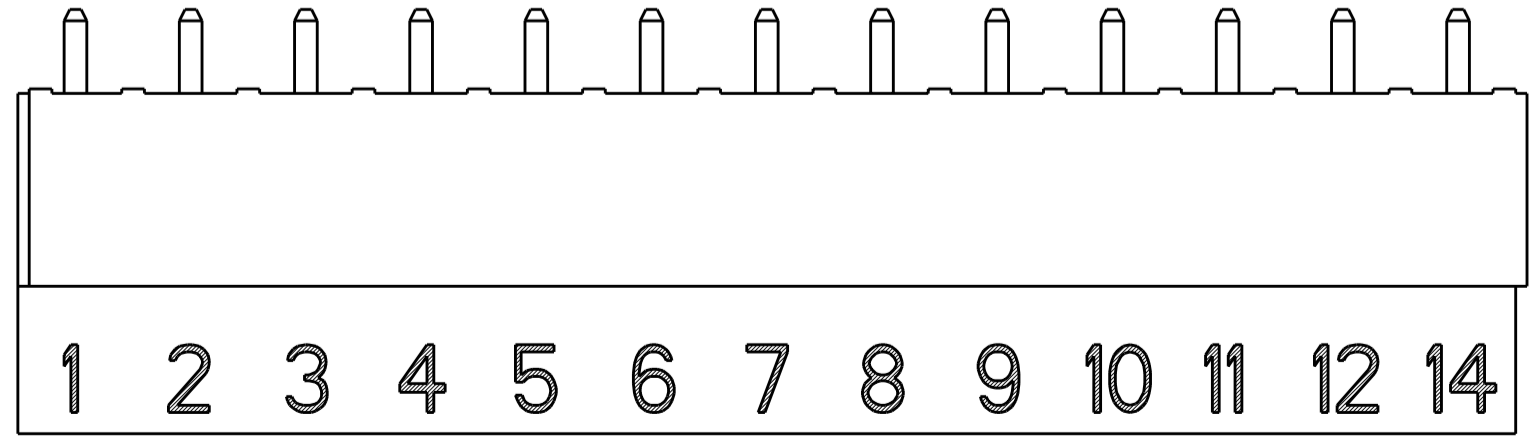

3-282841-2 AS SHOWN  $\triangle 8$

- $\triangle 1$  MATERIALS AND FINISH:  
 HOUSING: PA 6-6, UL 94-V0, COLOR: SEE TABLE.  
 CLAMP: BRASS, NICKEL PLATED.  
 TERMINAL: BRASS, TIN PLATED.  
 CLAMPING SCREW: M3, BRASS, NICKEL PLATED.
2. SUITABLE FOR 1,6-2,4mm. PCB THICKNESS.
3. END-TO-END STACKABLE W/INTERLOCK WITHOUT LOSS OF CENTERLINE SPACING.
4. WIRE SIZE RANGE: 12-30 AWG
5. RECOGNIZED UNDER THE COMPONENT PROGRAM OF UNDERWRITERS LABORATORIES INC. FILE No E60677.
6. IMQ CERTIFICATE WITH SURVEILLANCE IN CONFORMITY WITH IEC 998-1/998-2-1.
- $\triangle 7$  NOT CUMULATIVE TOLERANCE.
- $\triangle 8$  INK MARKING : BLACK COLOR.
9. BUCHANAN LOGO TO APPEAR ON HOUSING, LOCATION OPTIONAL, WHERE SPACE PERMITS.

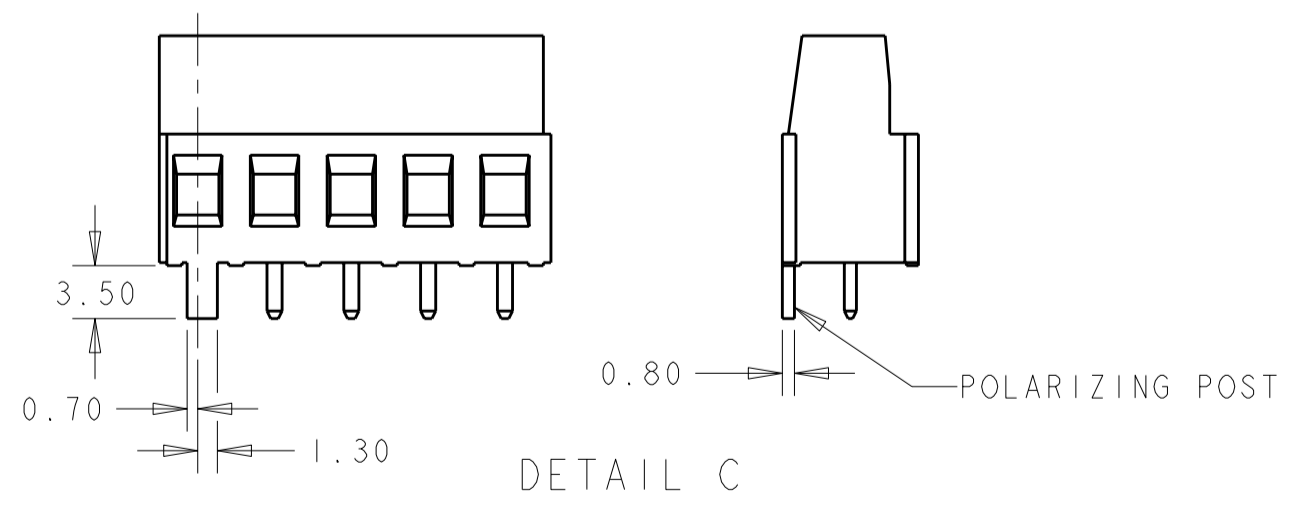
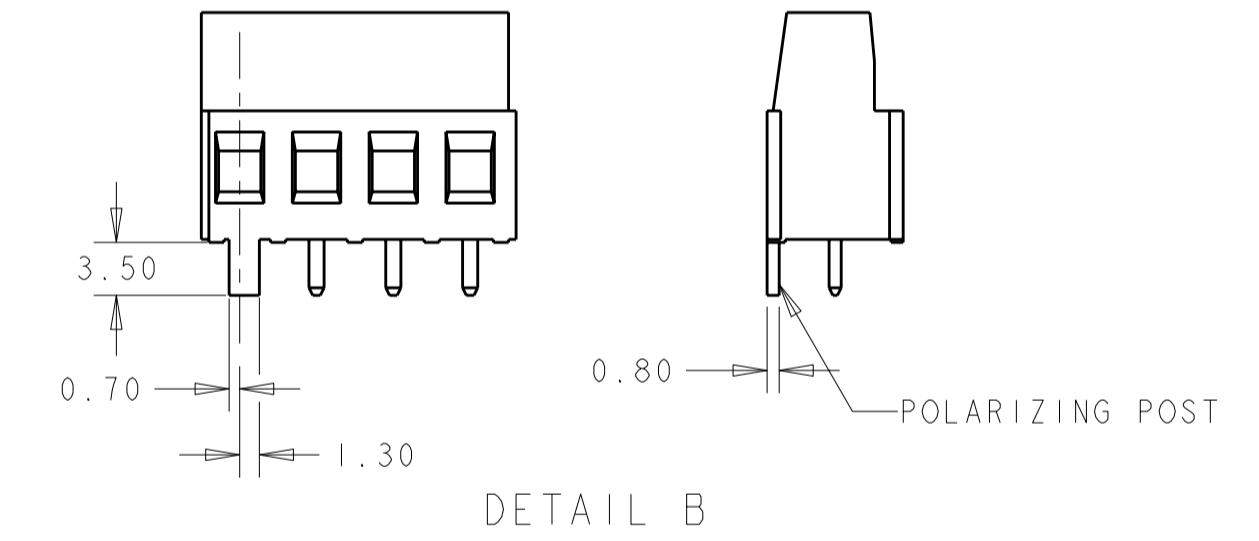

|  |  |                               |  |  |
|--|--|-------------------------------|--|--|
| THIS DRAWING IS A CONTROLLED DOCUMENT. |  | DWN S. WELDON 26 JAN 2001     | <b>STE</b> TE Connectivity                               |  |
| DIMENSIONS: mm                         |  | CHK D. BIEVENOUR 26 JAN 2001  |  |  |
| TOLERANCES UNLESS OTHERWISE SPECIFIED: |  | APVD D. BIEVENOUR 26 JAN 2001 | NAME: TERMINAL BLOCK PCB MOUNT W/INTERLOCK, 5.08mm PITCH |  |
| 0 PLC $\pm 0$                          |  | PRODUCT SPEC                  | SIZE: A2   |  |
| 1 PLC $\pm 3$                          |  | APPLICATION SPEC              | CAGE CODE: 200779  |  |
| 2 PLC $\pm 25$                         |  | WEIGHT                        | DRAWING NO: 282841                                       |  |
| 3 PLC $\pm 0$                          |  | CUSTOMER DRAWING              | RESTRICTED TO: -   |  |
| 4 PLC $\pm 0$                          |  | SCALE: 3:1                    | SHEET 2 OF 2   |  |
| ANGLES $\pm 2^\circ$                   |  |                               | REV. H6  |  |
| FINISH                                 |  |                               |  |  |